

JD-78ZYT16-9503T

Magnet (磁铁): Ferrite 铁氧体
 Insulation Class 绝缘等级: B , F
 Protection 防护等级: No
 Shaft OD 出轴直径: 8 ~ 12mm
 Bearing 轴承: Ball / Sleeve
 Winding 绕线选择:
 1. 工作电压范围: 6 ~ 36VDC
 2. 额定转速范围: 2,000 ~ 8000 RPM
 3. 输出功率范围: 30 ~ 300 W

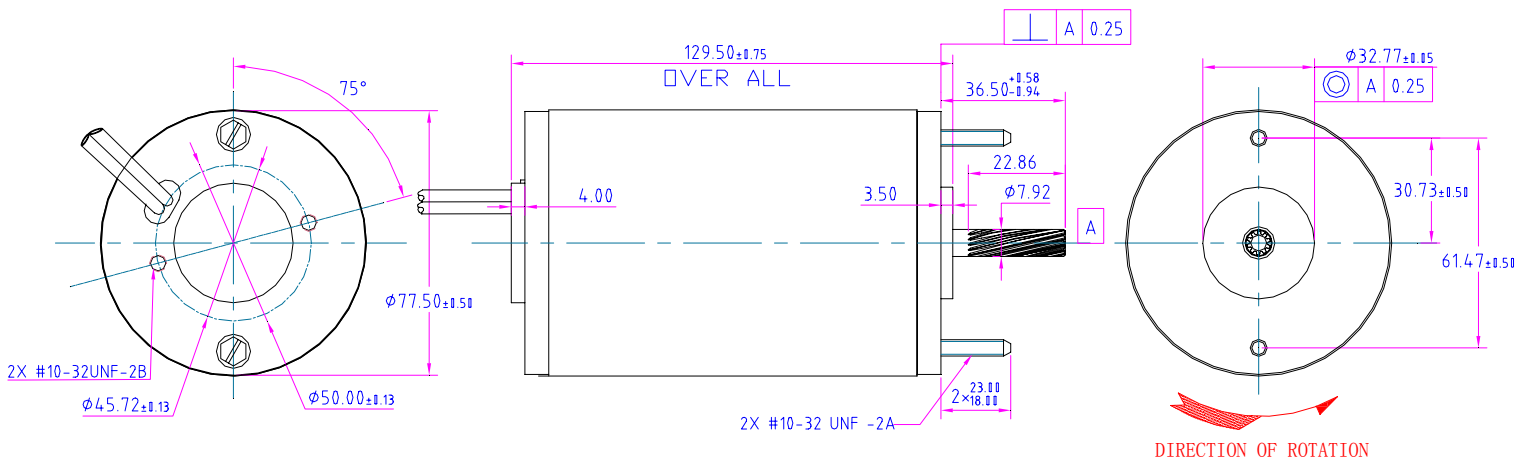

• **Motor Dimensions (外形尺寸图)**



• **Motor Test Curve (电机特性曲线)**

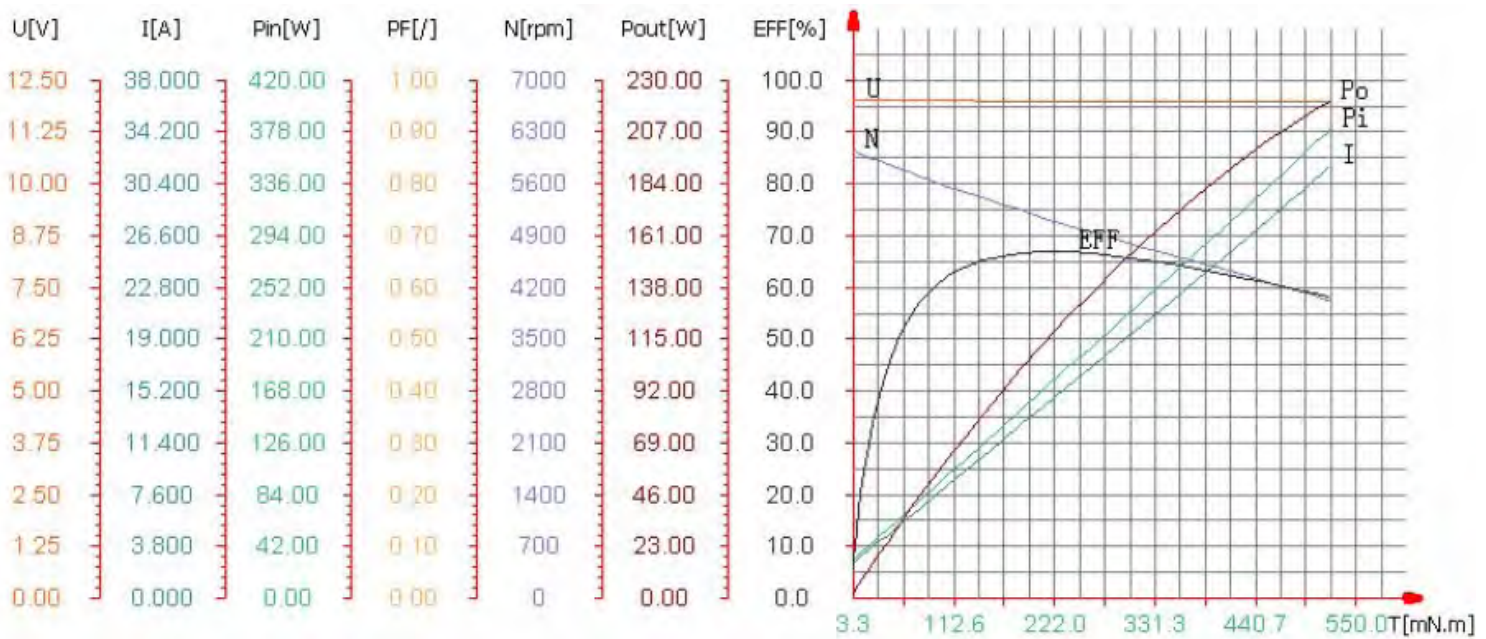

Jundi DC Motor CO.,LTD

• Motor Dynamic Test Data (电机动态测试数据)

项次 NO.	电压V	电流A	输入功率W	功率因数PF	频率Hz	转矩mN.m	转速rpm	输出功率W	效率%
1	12.04	2.567	30.56	1.000	0.00	3.3	6042	2.09	6.8
2	12.04	2.572	30.62	1.000	0.00	3.3	6042	2.09	6.8
3	12.04	2.567	30.59	1.000	0.00	3.3	6053	2.09	6.8
4	12.04	2.561	30.49	1.000	0.00	3.3	6052	2.09	6.9
5	12.04	2.562	30.47	1.000	0.00	3.3	6049	2.09	6.9
6	12.04	2.550	30.29	1.000	0.00	3.3	6047	2.09	6.9
7	12.04	2.564	30.48	1.000	0.00	3.4	6052	2.15	7.1
8	12.04	2.593	30.89	1.000	0.00	3.7	6052	2.34	7.6
9	12.04	2.752	32.78	1.000	0.00	4.6	6042	2.91	8.9
10	12.04	2.774	33.11	1.000	0.00	6.4	6032	4.04	12.2
11	12.04	2.996	36.01	1.000	0.00	8.9	6016	5.61	15.6
12	12.03	3.243	38.74	1.000	0.00	15.0	6000	9.42	24.3
13	12.03	3.409	41.18	1.000	0.00	16.6	5980	10.39	25.2
14	12.03	3.785	45.57	1.000	0.00	25.1	5932	15.59	34.2
15	12.03	4.142	49.96	1.000	0.00	32.2	5901	19.90	39.8
16	12.03	4.670	56.30	1.000	0.00	41.3	5886	25.45	45.2
17	12.03	5.226	62.71	1.000	0.00	49.5	5811	30.12	48.0
18	12.03	5.810	69.80	1.000	0.00	61.0	5758	36.78	52.7
19	12.02	6.559	78.95	1.000	0.00	74.7	5696	44.55	56.4
20	12.02	7.451	89.49	1.000	0.00	92.2	5637	54.42	60.8
21	12.02	8.280	99.46	1.000	0.00	109.1	5576	63.70	64.0
22	12.01	9.328	112.14	1.000	0.00	122.1	5501	70.33	62.7
23	12.01	10.351	124.51	1.000	0.00	142.5	5416	80.81	64.9
24	12.00	11.573	139.01	1.000	0.00	164.5	5333	91.86	66.1
25	12.00	12.743	153.01	1.000	0.00	187.3	5243	102.83	67.2
26	11.99	14.015	168.34	1.000	0.00	207.7	5126	111.48	66.2
27	11.99	15.502	186.15	1.000	0.00	234.2	5058	124.04	66.6

地址：浙江省余姚市经济开发区B区横三路。TEL：0574-62820655/62831828，FAX：0574-62823099

E-mail：jundi@mail.nbptt.zj.cn / jundi@vip.163.com 网址：<http://www.jdmotor.com>

