

JD-52ZYT10-8011

Magnet (磁铁): Ferrite 铁氧体
 Insulation Class 绝缘等级: B , F
 Protection 防护等级: No
 Shaft OD 出轴直径: 8 ~ 12mm
 Bearing 轴承: Ball / Sleeve
 Winding 绕线选择:
 1. 工作电压范围: 6 ~ 36VDC
 2. 额定转速范围: 2,000 ~ 15,000 RPM
 3. 输出功率范围: 25 ~ 120 W

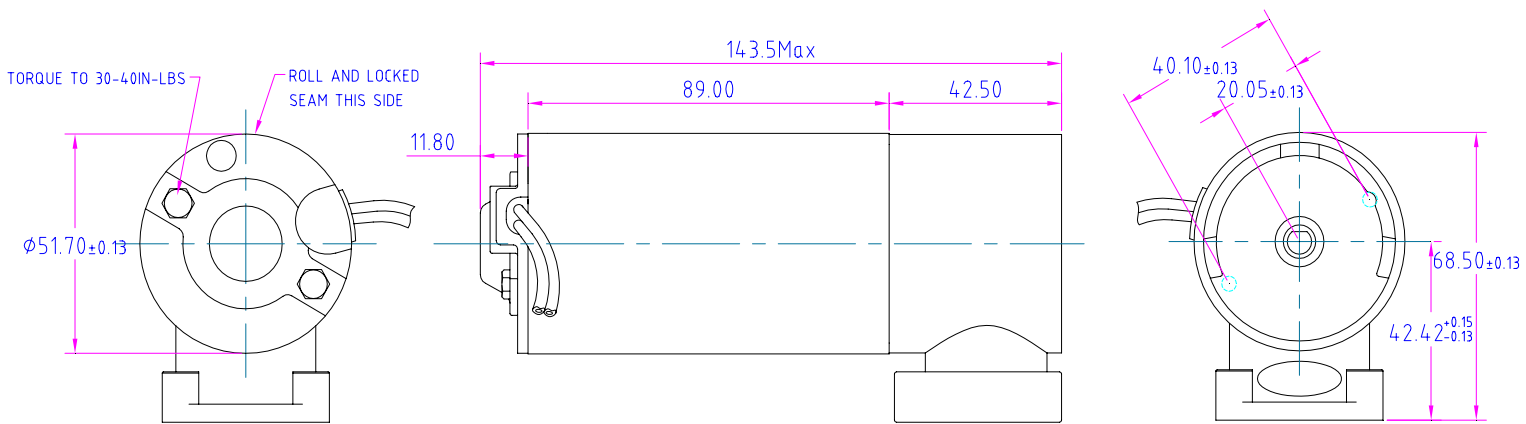

Motor Dimensions (外形尺寸图)



Motor Test Curve (电机特性曲线)

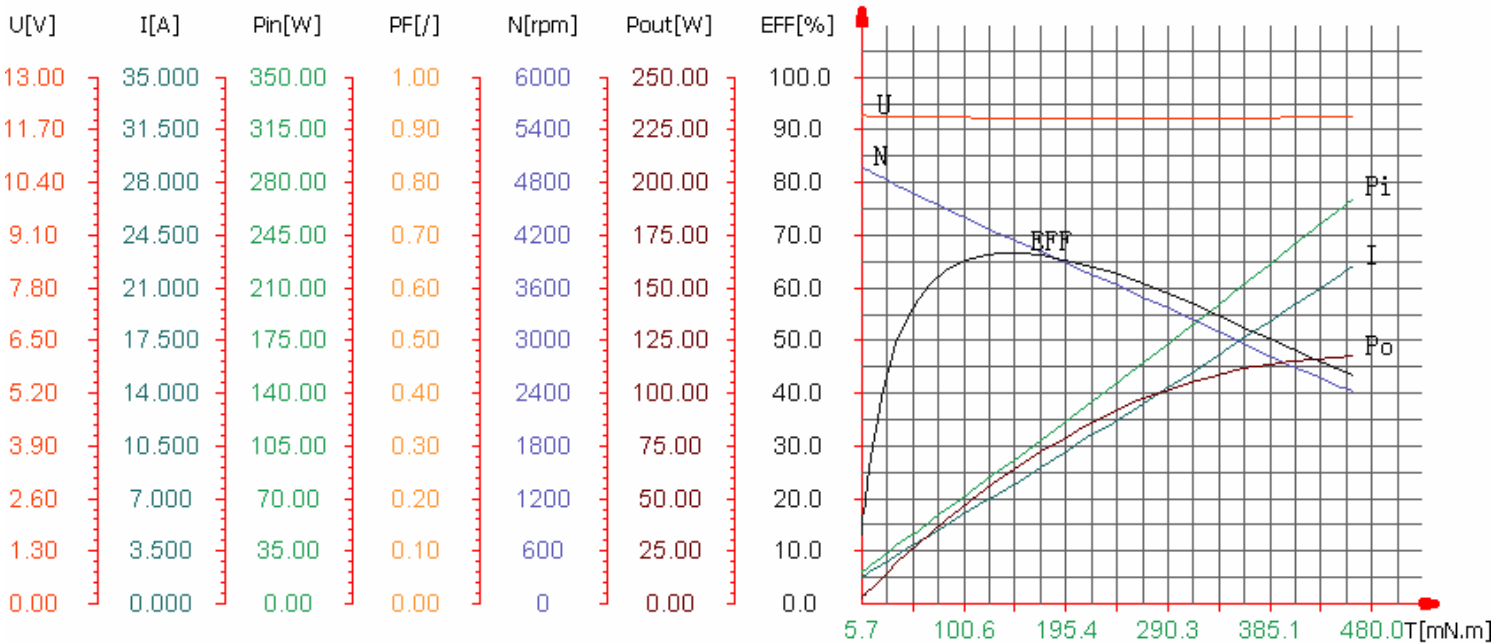

Jundi DC Motor CO.,LTD

• Motor Dynamic Test Data (电机动态测试数据)

项次 No:	电压 V	电流 A	输入功率 W	功率因数 PF	频率 Hz	转矩 N.m	转速 rpm	输出功率 W	效率 %
1	12.05	1.813	21.09	1	0	0.0057	4971	2.97	14.1
2	12.05	1.814	21.09	1	0	0.0057	4970	2.97	14.1
3	12.05	1.813	21.08	1	0	0.0057	4971	2.97	14.1
4	12.05	1.813	21.09	1	0	0.0057	4971	2.97	14.1
5	12.05	1.813	21.09	1	0	0.0057	4971	2.97	14.1
6	12.05	1.816	21.13	1	0	0.0057	4970	2.97	14.0
7	12.05	1.826	21.28	1	0	0.0059	4969	3.07	14.4
8	12.05	1.857	21.70	1	0	0.0067	4963	3.48	16.0
9	12.05	1.907	22.31	1	0	0.0076	4956	3.94	17.7
10	12.05	2.077	24.43	1	0	0.0095	4943	4.92	20.1
11	12.05	2.188	25.84	1	0	0.0154	4924	7.94	30.7
12	12.05	2.390	28.32	1	0	0.0170	4883	8.69	30.7
13	12.04	2.566	30.60	1	0	0.0241	4866	12.28	40.1
14	12.04	2.911	34.68	1	0	0.0308	4835	15.59	45.0
15	12.04	3.180	38.12	1	0	0.0366	4770	18.28	48.0
16	12.04	3.630	43.43	1	0	0.0465	4710	22.93	52.8
17	12.03	4.098	49.11	1	0	0.0569	4646	27.68	56.4
18	12.03	4.591	55.09	1	0	0.0694	4574	33.24	60.3
19	12.02	5.191	62.29	1	0	0.0834	4505	39.34	63.2
20	12.01	5.811	69.78	1	0	0.1010	4416	46.70	66.9
21	12.01	6.548	78.56	1	0	0.1127	4354	51.38	65.4
22	12.00	7.278	87.30	1	0	0.1313	4241	58.31	66.8
23	12.00	8.150	97.83	1	0	0.1512	4102	64.94	66.4
24	11.99	9.090	109.01	1	0	0.1751	4002	73.38	67.3
25	11.99	9.993	119.89	1	0	0.1904	3885	77.46	64.6
26	11.99	11.033	132.32	1	0	0.2140	3788	84.88	64.2
27	11.99	11.998	143.96	1	0	0.2384	3629	90.59	62.9

地址：浙江省余姚市经济开发区B区横三路。TEL：0574-62820655/62831828，FAX：0574-62823099

E-mail: jundi@mail.nbptt.zj.cn / jundi@vip.163.com 网址: <http://www.jdmotor.com>

